

Technical Data	DDS 4013	DDS 2090
Bending Length (B) (mm)	1300	900
Bending Capacity (ton)	40	20
Daylight (Q) (mm)	375	375
Maximum Stroke (mm)	150	150
Y Axis (Approaching/Bending/Return) Velocity (mm/sec)	150/20/150	150/20/150
Motor Power (kW)	2x3,8	3,8
Lenght (A) (mm)	1880	1280
Width (C) (mm)	2435	1760
Height (D) (mm)	2320	2190
Weight (Appr.) (kgs)	3400	2000

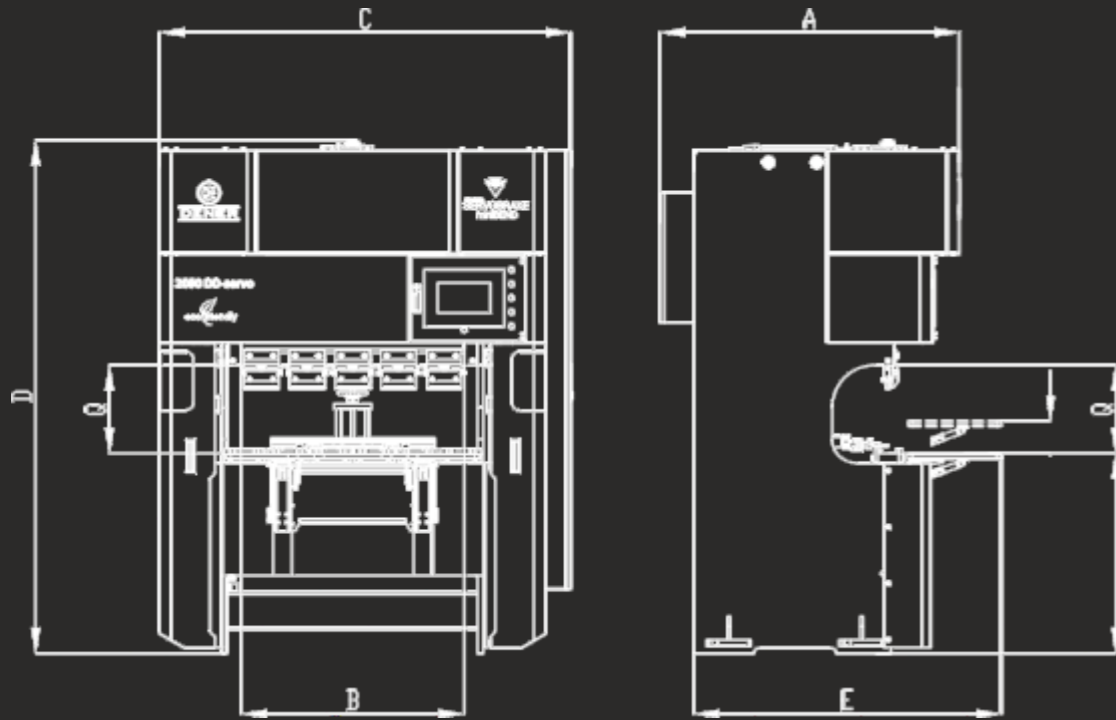

BALL-SCREW PRESS BRAKE
Compact Bending Solutions with High Efficiency



Sultansazi Organize Sanayi Bölgesi
6. Sokak No:12 İncesu/KAYSERİ





DENER

- +90 352 321 13 50
- +90 352 321 13 53
- info@dener.com
- www.dener.com



BALL-SCREW PRESS BRAKE

Single / Dual Lenze drive technology

-  Energy saving up to 50%
-  High speed bending produces more parts per hour
-  Low maintenance cost
-  High accuracy positioning and repeatability
-  Light and compact design

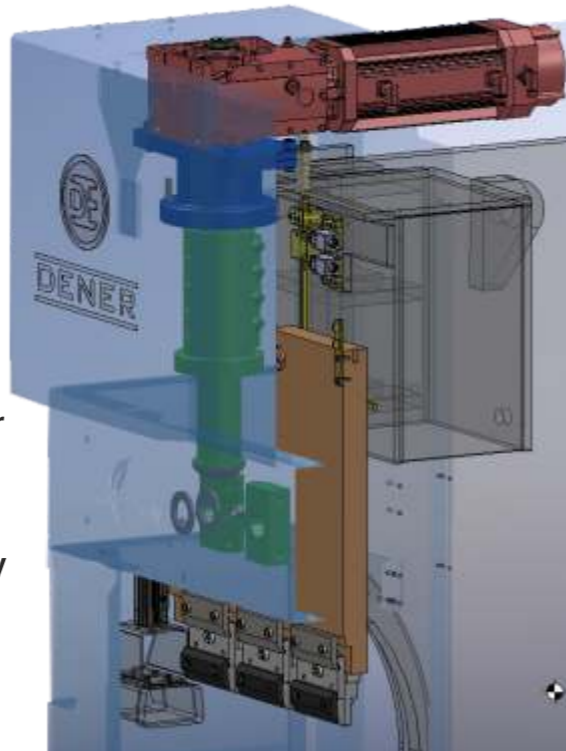

WORLDS WIDEST RANGE OF ELECTRICAL PRESS BRAKES



Control Unit

ESA S 630 Control Unit

- 10" color touch screen
- Automatic bend sequence
- Easy programmable 2D graphic display.
- Up to 4 axes (Y1,Y2, X and R)
- Multiple language options
- 2D Simulation
- Remote access

ESA S 660 3D Control Unit (Optional)



Back Gauge

- 2 axis back gauge handles complex parts with ease. (5 axis optional - Z1, Z2 and X-Prime with ESA660 controller)
- High speed movement combined with high accuracy drives ensures the back gauge is positioned quickly and precisely every time for the operator.

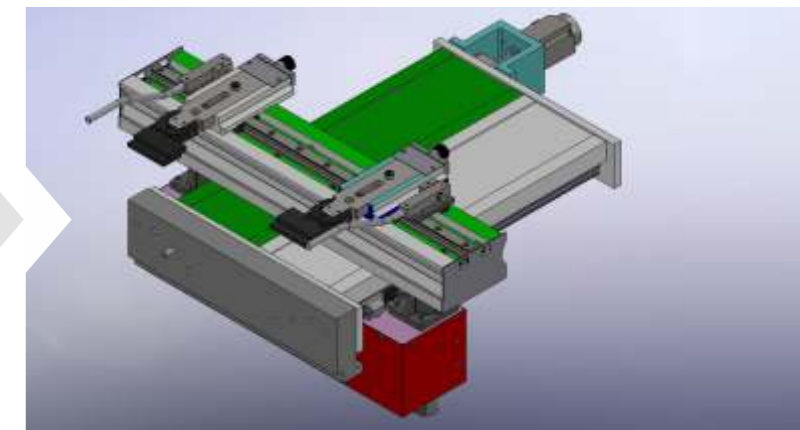

Work Table (Optional)

Foldable and height adjustable ergonomic working table makes bending easier and comfortable.



Safety System

Front laser finger protection system with safety PLC (Optional).



Other Advantages

- Electrical cabinet cooler
- Easier box bending with larger open height
- Quick installation and transportation

Clamping & Tools

Euro Type punch and die clamping systems.
Wila mechanical and hydraulic clamping system (Optional)



Body Frame

Solid monoblock body with small C frame gap provide high precision on bending.

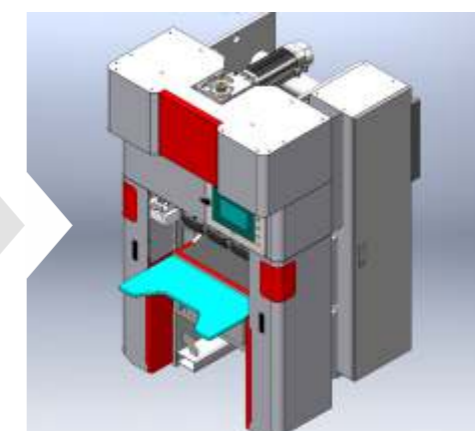

NO HYDRAULIC OIL CYLINDERS