

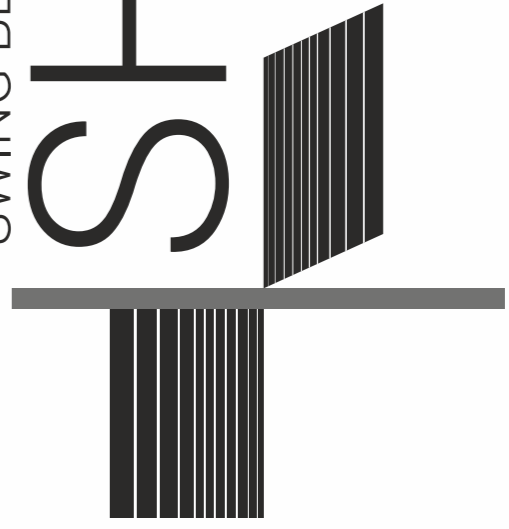

DENER MAKİNA SAN. TİC. LTD. A.Ş

- +90 352 321 13 50
- +90 352 321 13 53
- Sultansazı Organize Sanayi Bölgesi
6. Sokak No:12 İncesu/KAYSERİ
- info@dener.com
- www.dener.com

SWING BEAM - GUILLOTINE SHEARING



DENER MAKİNA, was established in 1974, in Kayseri / TURKEY. It has been manufacturing sheet metal working machines like Fiber Laser Cutting, Servo Electric Press Brake, Ball Screw Press Brake, Hydraulic Press Brakes, Hybrid Press Brake, NC - CNC Hydraulic Shears and Plasma Cutting machines.

Dener Makina's production facilities are located in the industrial and Freezone Area in Kayseri. Since it's beginning, Dener has the philosophy of production with the best quality and latest technology. It crowns this with the ISO 9001 Quality Management System and following European Safety Standards. Dener Makina is a leading Turkish Brand in Sheet Metal Working Machinery. It has qualified workmanship and a complete machinery manufacturing facility in it's 30.000 m2 closed area. Today, Dener machines are working all around the world.



04	AS SERIES CNC GUILLOTINE SHEAR
06	STANDARD EQUIPMENTS
10	OPTIONAL EQUIPMENTS
12	AS SERIES TECHNICAL SPECIFICATIONS
16	BS SERIES NC SWING BEAM SHEAR
18	STANDARD EQUIPMENTS
20	OPTIONAL EQUIPMENTS
22	BS SERIES TECHNICAL SPECIFICATIONS



AS SERIES CNC GUILLOTINE SHEAR

Dener CNC Guillotine Shears provide, rock solid mechanics, hydraulic, accurate ball screw back gauge, userfriendly CNC Controller high productive shearing machines. Dener Shears are starring form 6 mm up to 20 mm thickness cutting length from 3 mt up to 6 mt as a standard and according to the special demanded higher capacity machines are available.

Dener Guillotine Shears have strong welded steel construction suitable for long operation time. The design of the frame, cutting beam and back gauge to ensure highest rigidity and resistance to torsions and deformations. With the strong design customers can get maximum cutting quality.

With Easy to use CNC controller operator enters the thickness and the type of the material and controller automatically adjust the cutting angel and blade gap.



AS SERIES

CNC GUILLOTINE SHEAR

**Optimal Solution
For Shearing.**



STANDARD EQUIPMENT

ESA S 630 CONTROLLER

- 10" LCD Touch Screen
- Back gauge control
- Blade gap control
- Cutting angle control
- Cutting length adjustment
- Programmable up to 100 steps
- Positioning correction
- Step repetition
- Inch/mm selection
- 2 USB (2.0) ports.
- 128 MB silicon disk.



FOOT PEDAL

Remote Foot Control Pedal with Emergency Stop Button

FRONT ARMS

Table Equipped With Sheet Slider Balls Operations Square Arm With Rear Supporting Nail in T-Slot Front Support Arms With T-Slots

STANDARD EQUIPMENTS



Sheet Slider



Motorized Back Gauge has $\pm 0,1$ mm Accuracy



Front Protection Frame



Hold Down Pads



AS SERIES



Excellent cutting quality from 6 mm up to 20 mm with powerful monoblock body



BLADE PADS SYSTEM

The Blade Pads System ensures linearity and accuracy in any condition, for the best cutting quality.



ADVANTAGES

- High stiffness frame
- Straight cutting quality
- New design body structure and working system
- Less maintenance
- Faster working system

AS SERIES OPTIONAL EQUIPMENTS

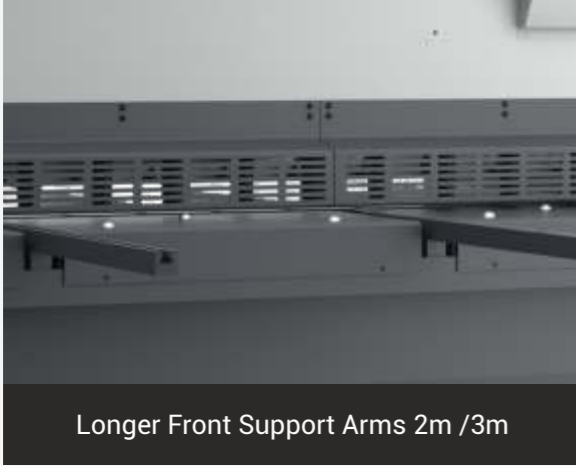

Longer Front Support Arms 2m /3m



Spare Blade



Hydraulic Oil Cooler System



Pneumatic Sheet Support System

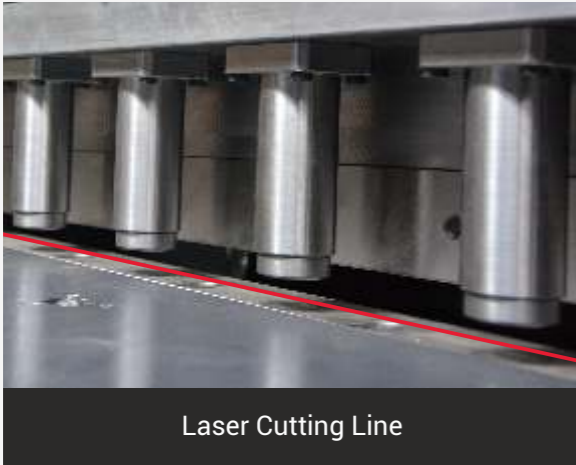

Laser Cutting Line

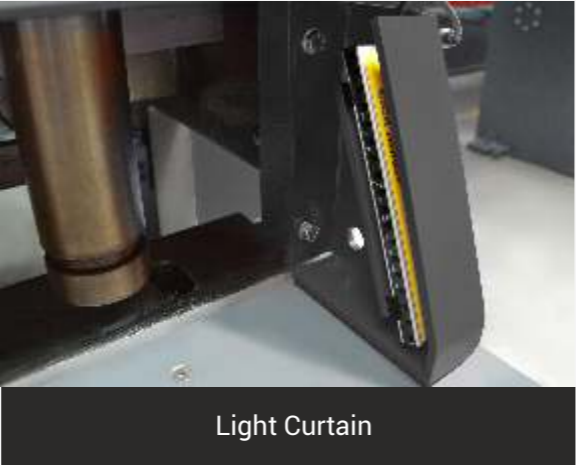

Light Curtain

AS OPTIMAL



CE
Confirmation
with Photocell
System

AS SERIES CNC GUILLOTINE SHEAR

		AS	AS	AS	AS	AS	AS	AS	AS	AS	AS	AS	AS	AS	AS	AS
		3006	3016	3013	3016	3020	4006	4010	4013	4016	4020	6006	6010	6013	6016	6020
Cutting Length	(mm)	3035	3040	3040	3060	3060	4065	4065	4065	4065	4065	6125	6125	6125	6160	6125
Cutting Capacity (Mild Steel)	(mm)	6	10	13	16	20	6	10	13	16	20	6	10	13	16	20
Cutting Angle	degree	0,5-3	0,5-3	0,5-3	0,5-3	0,5-3	0,5-3	0,5-3	0,5-3	0,5-3	0,5-3	0,5-2,5	0,5-2,5	0,5-2,5	0,5-2,5	0,5-2,5
Hold Down Pad Number	pcs	15	17	16	16	16	23	21	21	26	26	31	31	31	31	31
Main Motor	kW	11	22	30	30	37	11	22	30	30	37	11	22	30	45	45
Cutting Pcs (0,5 - 3°)	cuts/min.	29-12	20-11	17-8	13-6	12-5	23-9	20-11	13-6	13-6	12-5	14-6	11-5	11-5	10-5	10-5
Oil Tank	lt	200	300	400	600	750	200	400	400	400	750	475	500	400	750	750
Length	L (mm)	3775	3850	3850	3870	3910	4830	4860	4850	4930	4950	6910	6930	7090	7200	7200
Throat Depth	E (mm)	350	350	350	350	350	350	350	350	350	350	350	350	350	350	350
Width Without Ruler	B (mm)	2300	2320	2350	2340	2370	2300	2220	2350	2300	2400	2200	2400	2400	2550	2700
Width	W (mm)	2955	2960	3270	3315	3395	2955	3170	3160	3300	3390	3610	3630	3185	3700	3700
Height	H (mm)	2260	2160	2260	2280	2640	2130	2430	2360	2200	2570	2780	2780	2665	2780	2780
Weight	Kg	8800	10700	13500	15800	20000	11500	14900	18500	21000	25000	27500	25000	35500	49500	55000

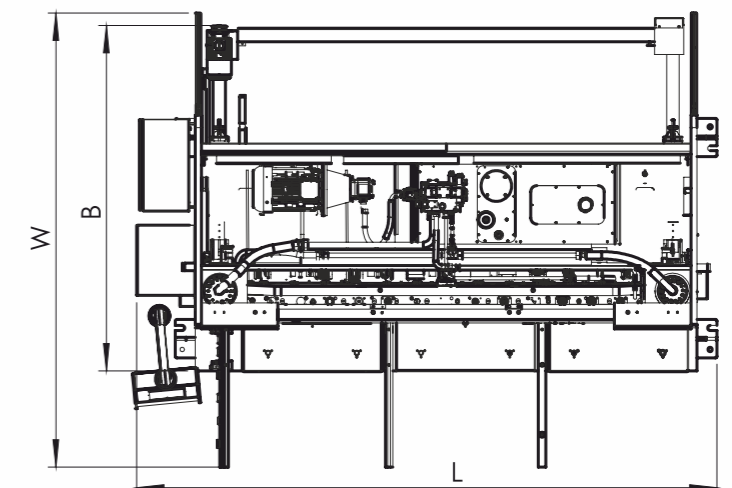
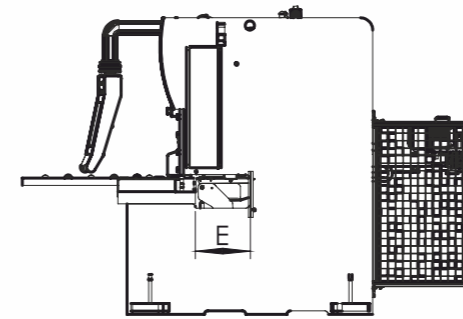
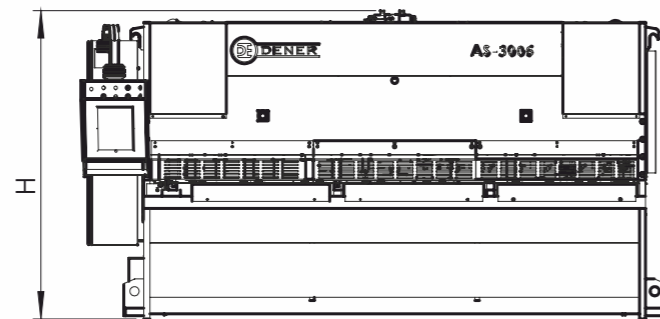

SPECIAL PROJECT DENER AS-8016 SHEAR



BS SERIES SWING BEAM SHEAR

Easy, accurate, rock solid welded steel construction proven design that thousands of customers across the world have come to rely on.

Dener Swing Beam Shears are starting from 6 mm up to 20 mm thickness and cutting length from 2 m up to 6 m as a standard and according to the special demanded higher capacity machines are available.

Main features of the Swing Beam Shears are; NC controller for Back Gauge, single point manual blade gap adjustment, 1000 mm motorized ball screw back gauge, cutting length adjustment by timer, 1 m flip up front guarding, Sheet support arms and squaring support, sheet slider table and back slider.



BS SERIES

SWING BEAM SHEAR



NC CONTROLLER

The HT 071 is a very compact, simply programmable single axis controller for swing beam shear. This unit has back gauge control, retract, and stroke counter and program memory up to 99 programs with 20 steps. Back gauge axis control is two speed Ac control. Referencing is not necessary controller always remember the last position. The back gauge can be moved manually by selecting push buttons in 2 different speeds. Total working hours and total cut counter is also standard with controller.

HT 071 FEATURING

- LCD display
- Back gauge control
- Actual position visualization
- Stock counter
- Program memory up to 99 parts
- Programmable up to 20 steps
- User-friendly one-touch programming
- Retract
- Semi automatic and automatic funtion.
- Stroke limitation



FOOT PEDAL

Remote Foot Control Pedal with Emergency Stop Button

FRONT ARMS

Table Equipped With Sheet Slider Balls Operations
Square Arm With Rear Supporting Nail in T-Slot Front
Support Arms With T-Slots

STANDARD EQUIPMENTS



Sheet Slider



Motorized Back Gauge has $\pm 0,1$ mm Accuracy



Front Protection Frame



Hold Down Pads



BS SERIES OPTIONAL EQUIPMENT



Longer Front Support Arms 2m /3m

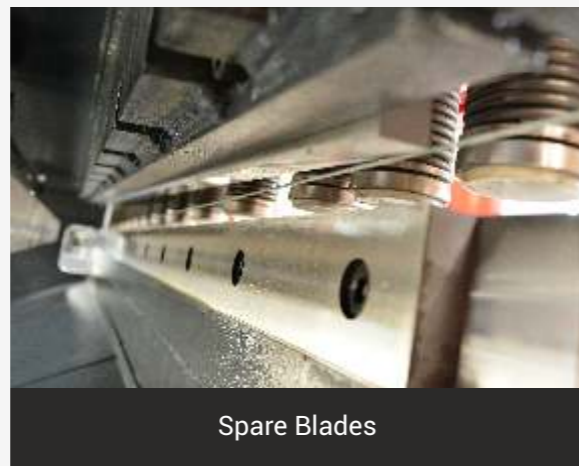

Spare Blades



Hydraulic Oil Cooler System



Pneumatic Sheet Support System



Motorized Blade Gap Adjustment with CNC Controller



Light Curtain

AS OF THE BS OPTIONAL

ESA S 530 CONTROLLER

- 7" LCD TFT display
- Back gauge control
- Blade gap control
- Cutting angel control
- Cutting length adjustment
- Programmable up to 100 steps
- Positioning correction
- Step repetition
- Inch/mm selection
- 2 serial port rs232.
- 2 USB (2.0) ports.
- 1 VGA port for external monitor connection
- 1 ethernet port 10/100 Mbit (lan connection)
- 128 MB silicon disk.
- 24Vdc power supply.



CNC Controller for Motorized Blade Gab Adjustment

BS SERIES NC SWING BEAM SHEAR

		BSY	BS	BS	BS	BS	BS	BS	BS	BS	BS	BS	BS	BS	BS	BS
		3006	3010	3013	3016	3020	4006	4010	4013	4016	4020	6006	6010	6013	6016	6020
Cutting Length	(mm)	3080	3120	3120	3120	3120	4160	4160	4160	4160	4160	6240	6240	6240	6240	6240
Cutting Capacity (Mild Steel)	(mm)	6	10	13	16	20	6	10	13	16	20	6	10	13	16	20
Cutting Angle	degree	1,39	2	2,5	2,5	2,5	1,33	2	2	2	2	1,33	1,5	1,5	1,5	1,5
Hold Down Pad Number	pcs	15	15	15	15	18	19	19	19	19	19	37	37	37	37	28
Main Motor	kW	11	22	30	30	37	11	22	30	30	37	11	22	30	37	37
Cutting Pcs	cuts/min.	18	12	12	12	9	14	8	8	8	6	4	4	4	4	4
Oil Tank	lt	200	200	400	400	475	240	240	400	400	475	475	475	600	600	600
Length	L (mm)	3840	3850	3850	3875	3950	4890	4910	4930	4950	4980	6910	6930	6950	6985	6985
Throat Depth	E (mm)	150	150	150	150	150	150	150	150	150	150	150	150	150	315	360
Width Without Ruler	B (mm)	2050	2175	2270	2350	2420	2050	2160	2345	2380	2400	2450	2480	2500	2500	2500
Width	W (mm)	2745	3060	3160	3200	3350	2750	3120	3160	3190	3350	3610	3630	3650	3700	3700
Height	H (mm)	1700	1850	2000	2170	2430	1820	2000	2100	2480	2600	2730	2730	2730	2730	2730
Weight	Kg	8800	12500	14000	16120	22000	8000	10500	1850	18400	25500	23000	25000	27750	34500	44950

