

HCL-Series, High Tonnage Lock Nut Cylinders

HCL-Series, Single-Acting, Gravity Return Cylinders

- Lock nut provides positive and safe mechanical load holding
- Low-friction locking rings spin easy, save time and effort
- Designed to withstand 10% side-load up to 90% of maximum stroke
- Hardened surface resists side-loading and cyclic wear
- Overflow port as stroke limiter to prevent plunger blow-out
- Weather protected, inside and out
- Replaceable bearings enclose the plunger for support throughout the stroke
- Certified lifting eyes and base mounting holes.

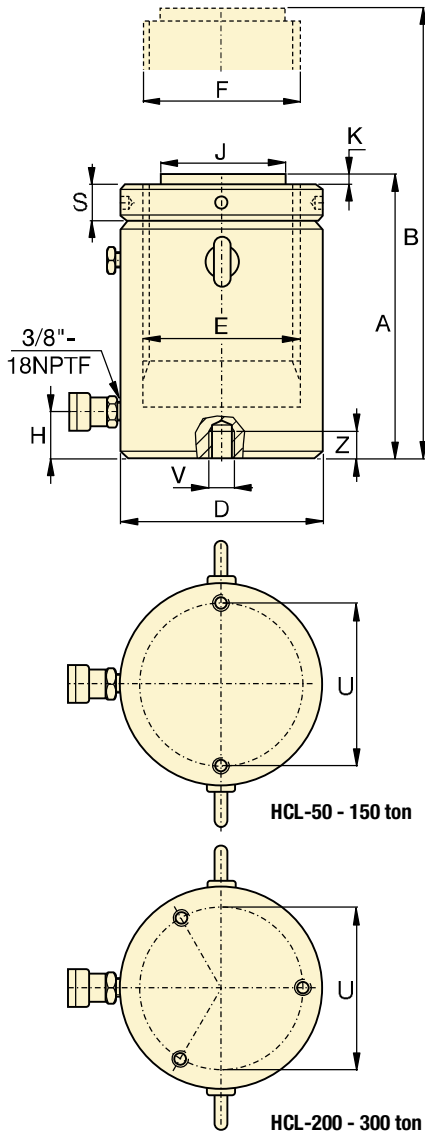

SELECTION CHART 50 - 300 TON HCL-MODELS

For 400 - 1000 ton models, see pages 54-55.

For full product features see pages 40-41.

Cylinder Capacity ton	Stroke (mm)	Model Number	Maximum Cylinder Capacity at 700 bar ton (kN)	Cylinder Effective Area (cm ²)	Oil Capacity (cm ³)	Collapsed Height A (mm)
50	50	HCL-502	56 (550)	78,5	393	164
	100	HCL-504			785	214
	150	HCL-506			1178	264
	200	HCL-508			1571	314
	250	HCL-5010			1963	364
	300	HCL-5012			2356	414
100	50	HCL-1002	102 (1002)	143,1	716	187
	100	HCL-1004			1431	237
	150	HCL-1006			2147	287
	200	HCL-1008			2863	337
	250	HCL-10010			3578	387
	300	HCL-10012			4294	437
150	50	HCL-1502	153 (1497)	213,8	1069	209
	100	HCL-1504			2138	259
	150	HCL-1506			3207	309
	200	HCL-1508			4276	359
	250	HCL-15010			5346	409
	300	HCL-15012			6415	459
200	50	HCL-2002	202 (1985)	283,5	1418	238
	100	HCL-2004			2835	288
	150	HCL-2006			4253	338
	200	HCL-2008			5671	388
	250	HCL-20010			7088	438
	300	HCL-20012			8506	488
250	50	HCL-2502	259 (2541)	363,1	1815	249
	100	HCL-2504			3631	299
	150	HCL-2506			5446	349
	200	HCL-2508			7261	399
	250	HCL-25010			9076	449
	300	HCL-25012			10.892	499
300	50	HCL-3002	310 (3036)	433,7	2169	278
	100	HCL-3004			4337	328
	150	HCL-3006			6506	378
	200	HCL-3008			8675	428
	250	HCL-30010			10.843	478
	300	HCL-30012			13.012	528

Base Mounting Holes (mm)					
Model / Capacity ton	Bolt Circle U	Thread Size V	Minimum Thread Depth Z	Number of Holes	Angle from Coupler
HCL-50	105	M8 x 1,25	10	2	90°
HCL-100	150	M12 x 1,75	17	2	90°
HCL-150	185	M12 x 1,75	22	2	90°
HCL-200	215	M12 x 1,75	22	3	60°
HCL-250	245	M12 x 1,75	22	3	60°
HCL-300	260	M16 x 2	25	3	60°

Single-Acting, Lock Nut Cylinders

Capacity:
50 - 300 ton

Stroke:
50 - 300 mm

Maximum Operating Pressure:
700 bar

HCL Series

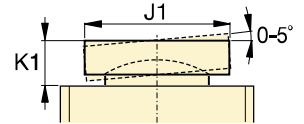

CAT-Series Tilt Saddle

	Extended Height B (mm)	Outside Diameter D (mm)	Cylinder Bore Diameter E (mm)	Plunger Diameter (threaded) F (mm)	Base to Advance Port H (mm)	Standard Saddle Diameter J (mm)	Saddle Protrusion from Plunger K (mm)	Lock Nut Height S (mm)	 (kg)	Model Number	Optional Tilt Saddle		
											Diameter J1 (mm)	Height K1 (mm)	Saddle Model Number
	214	130	100	Tr 100 x 4	24	71	2	25	17	HCL-502	71	24	CAT-100
	314								22	HCL-504			
	414								27	HCL-506			
	514								32	HCL-508			
	614								38	HCL-5010			
	714								43	HCL-5012			
	237	175	135	Tr 135 x 6	33	71	2	33	35	HCL-1002	71	24	CAT-100
	337								44	HCL-1004			
	437								54	HCL-1006			
	537								63	HCL-1008			
	637								73	HCL-10010			
	737								82	HCL-10012			
	259	215	165	Tr 165 x 6	41	130	2	40	59	HCL-1502	130	19	CAT-200
	359								73	HCL-1504			
	459								87	HCL-1506			
	559								102	HCL-1508			
	659								116	HCL-15010			
	759								130	HCL-15012			
	288	250	190	Tr 190 x 6	47	130	2	45	85	HCL-2002	130	19	CAT-200
	388								105	HCL-2004			
	488								124	HCL-2006			
	588								143	HCL-2008			
	688								163	HCL-20010			
	788								182	HCL-20012			
	299	280	215	Tr 215 x 6	53	150	2	52	119	HCL-2502	150	19	CAT-250
	399								143	HCL-2504			
	499								167	HCL-2506			
	599								192	HCL-2508			
	699								216	HCL-25010			
	799								240	HCL-25012			
	328	305	235	Tr 235 x 6	58	140	2	56	158	HCL-3002	195	73	CAT-300
	428								186	HCL-3004			
	528								215	HCL-3006			
	628								244	HCL-3008			
	728								272	HCL-30010			
	828								301	HCL-30012			

HCL-Series, High Tonnage Lock Nut Cylinders

HCL-Series, Single-Acting, Gravity Return Cylinders

- Lock nut provides positive and safe mechanical load holding
- Low-friction locking rings spin easy, save time and effort
- Designed to withstand 10% side-load up to 90% of maximum stroke
- Hardened surface resists side-loading and cyclic wear
- Overflow port as stroke limiter to prevent plunger blow-out
- Weather protected, inside and out
- Replaceable bearings enclose the plunger for support throughout the stroke
- Certified lifting eyes and base mounting holes.

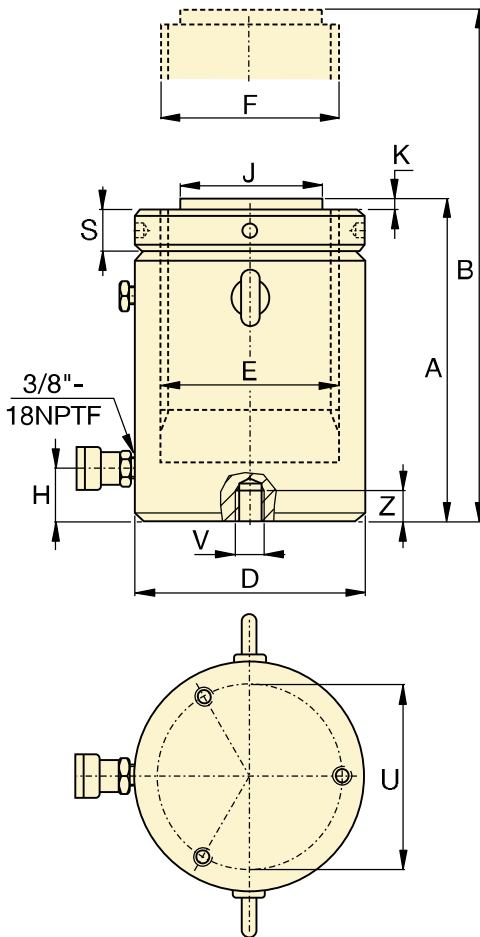

SELECTION CHART 400 - 1000 TON HCL-MODELS

For 50 - 300 ton models, see pages 52-53.
For full product features see pages 40-41.

Cylinder Capacity	Stroke	Model Number	Maximum Cylinder Capacity at 700 bar ton (kN)	Cylinder Effective Area	Oil Capacity	Collapsed Height
ton	(mm)			(cm ²)	(cm ³)	A (mm)
400	50	HCL-4002	409 (4008)	572,6	2863	317
	100	HCL-4004			5726	367
	150	HCL-4006			8588	417
	200	HCL-4008			11.451	467
	250	HCL-40010			14.314	517
	300	HCL-40012			17.177	567
500	50	HCL-5002	522 (5114)	730,6	3653	357
	100	HCL-5004			7306	407
	150	HCL-5006			10.959	457
	200	HCL-5008			14.612	507
	250	HCL-50010			18.265	557
	300	HCL-50012			21.918	607
600	50	HCL-6002	611 (5987)	855,3	4276	380
	100	HCL-6004			8553	430
	150	HCL-6006			12.829	480
	200	HCL-6008			17.106	530
	250	HCL-60010			21.382	580
	300	HCL-60012			25.659	630
800	50	HCL-8002	831 (8149)	1164,2	5821	430
	100	HCL-8004			11.642	480
	150	HCL-8006			17.462	530
	200	HCL-8008			23.283	580
	250	HCL-80010			29.104	630
	300	HCL-80012			34.925	680
1000	50	HCL-10002	1085 (10.644)	1520,5	7603	484
	100	HCL-10004			15.205	534
	150	HCL-10006			22.808	584
	200	HCL-10008			30.411	634
	250	HCL-100010			38.013	684
	300	HCL-100012			45.616	734

Base Mounting Holes (mm)					
Model / Capacity ton	Bolt Circle U	Thread Size V	Minimum Thread Depth Z	Number of Holes	Angle from Coupler
HCL-400	300	M16 x 2	25	3	60°
HCL-500	340	M24 x 3	36	3	60°
HCL-600	370	M24 x 3	36	3	60°
HCL-800	440	M24 x 3	36	3	60°
HCL-1000	500	M24 x 3	36	3	60°

Single-Acting, Lock Nut Cylinders



▲ Heavy lifting and foundation levelling. The lock nut provides mechanical load holding over a long period of time.

HCL Series



Capacity:
400 - 1000 ton

Stroke:
50 - 300 mm

Maximum Operating Pressure:
700 bar

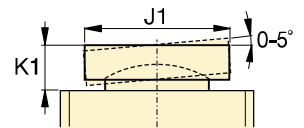

CAT-Series Tilt Saddle

Extended Height B (mm)	Outside Diameter D (mm)	Cylinder Bore Diameter E (mm)	Plunger Diameter (threaded) F (mm)	Base to Advance Port H (mm)	Standard Saddle Diameter J (mm)	Saddle Protrusion from Plunger K (mm)	Lock Nut Height S (mm)	 (kg)	Model Number	Optional Tilt Saddle			
										Diameter J1 (mm)	Height K1 (mm)	Model Number	
367	350	270	Tr 270 x 6	67	159	5	65	236	HCL-4002	225	85	CAT-400	
467								274					HCL-4004
567								311					HCL-4006
667								349					HCL-4008
767								387					HCL-40010
867								425					HCL-40012
407	400	305	Tr 305 x 6	75	179	5	72	341	HCL-5002	250	91	CAT-500	
507								390					HCL-5004
607								439					HCL-5006
707								489					HCL-5008
807								538					HCL-50010
907								587					HCL-50012
430	430	330	Tr 330 x 6	81	194	5	80	427	HCL-6002	275	99	CAT-600	
530								484					HCL-6004
630								541					HCL-6006
730								598					HCL-6008
830								655					HCL-60010
930								712					HCL-60012
480	505	385	Tr 385 x 6	95	224	5	90	668	HCL-8002	320	124	CAT-800	
580								746					HCL-8004
680								825					HCL-8006
780								904					HCL-8008
880								982					HCL-80010
980								1061					HCL-80012
534	570	440	Tr 440 x 6	110	249	5	105	959	HCL-10002	360	136	CAT-1000	
634								1059					HCL-10004
734								1160					HCL-10006
834								1260					HCL-10008
934								1360					HCL-100010
1034								1460					HCL-100012